

FEM3500/FEM3500D/FEM3500M/FEM3500DM

Electromagnetic Lock

Electro-Magnetic Lock Description:

The FEM3500 is an unmonitored single magnetic lock and FEM3500D is an unmonitored double magnetic lock with dual 12 or 24 volt settings. There are no Lock or Door status sensors on these units. For wiring instruction refer to figure 2.

The FEM3500M is a monitored single magnetic lock and the FEM3500DM is a monitored double magnetic lock with 12 or 24 volt settings. Each magnetic lock has a built-in Hall crystal for remote monitoring of Lock status (open or closed) through relay contacts rated at 24 VDC, 1.0 A max on visible high luminosity backlight indicator position on the aluminum housing and a Door Status Sensors (DSS) for remote monitoring of Door status through reed switch contact. For wiring instruction refer to Figure 1.

Backlight Indicator OFF	Relay De-energized,	No Power on Magnetic Lock
Backlight Indicator RED	Relay De-energized,	Power on Magnetic Lock and Door is Open.
Backlight Indicator GREEN	Relay Energized,	Power on Magnetic Lock and Door Locked.

Power setting and Input

Power Input	FEM3500/ FEM3500M	FEM3500D/ FEM3500DM
12 VDC	0.50 A	2 x 0.50 A
24 VDC	0.25 A	2 x 0.25 A

The (+) lead of the power source is connected to Pins 1 (VDC +) of the terminal block and the (-) lead is connected to Pin 2 (-). The operating switch or controlling contacts must be installed between the power source and the magnetic lock to reduce operating time of the magnetic lock to a minimum. The electromagnetic lock requires a filtered and regulated DC Power Source for optimal performance.

Remove the wiring cavity cover plate and check the position of the two shunts located on the PCB. A single shunt across pins 2 and 3 will set the operating voltage to 24 volts. A shunt between pins 1 to 2 and a shunt between pins 3 to 4 sets the operating voltage to 12 volts.

These voltage shunts must be set correctly before 12 VDC or 24 VDC power is supplied to the Electromagnetic Lock to prevent damage to the unit.

Wiring connections:

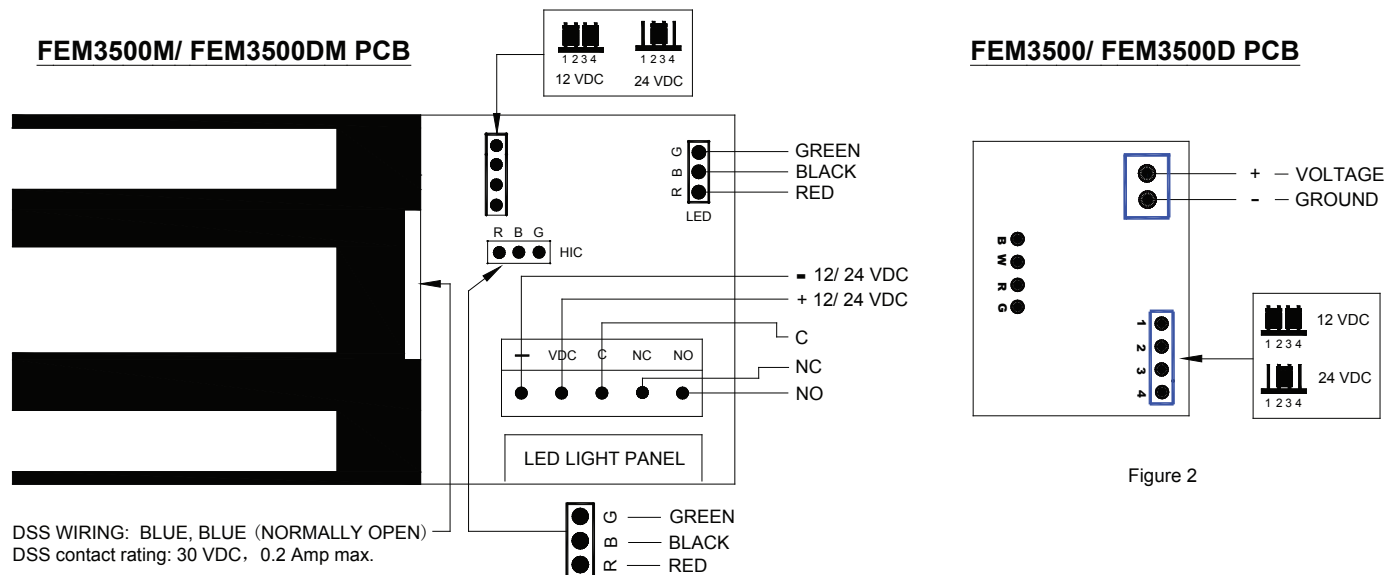

Figure 2

Figure 1

Installation Tips

Armature Plate must remain flexible

The armature plate must be remained movable to allow surface alignment with the magnet face. The Magnetic Lock will lose holding force without this floating alignment.

Do not trim the rubber washers

Trimming rubber washers will adversely affect the release of the armature plate from the magnetic lock.

Important Safety Requirements

1. Apply thread-locker glue (i.g. Loctite) to the thread of the Armature-Plate-Fixing Screw (Allen-Screw) to prevent from becoming loose.
2. Locks should be inspected at regular intervals to ascertain the safety functionality in conjunction with the door environment.
3. The supplied Allen screws cater for maximum door-thickness of 45mm.

Trouble Shooting

Problem	Possible Cause	Solution
Door will not lock	No DC voltage to lock. Loose wire on terminal strip.	Check power supply and wiring to magnetic lock. Check for voltage at terminal block of magnetic lock.
Reduced holding force	Bad physical contact between armature plate and face of magnet.	Ensure mating surfaces are clean and in proper alignment and the armature plate floats freely. Check magnetic lock for low voltage or wrong voltage setting.
Delay in door release	Circuit switch is not between magnetic lock and power source. Secondary diode installed across magnetic lock.	Re-wire circuit switch between magnetic lock and power source. Remove this diode. Voltage spike protection is on the PCB.
Light panel Status is incorrect	Misalignment of armature plate. Hall effect switch has moved inside the magnetic block.	Check alignment of armature plate. Reposition reed switch; contact manufacturer for instruction.

Maintenance

Contacting surface of the Electromagnet and Armature plate must be kept free of contaminating materials. Surfaces should be cleaned periodically with a non-abrasive cleaner. Do not spray the Electromagnet or Armature plate surface with any lacquer chemical, this will create problems with the release of the magnetic lock and Armature plate and might cause serious safety problems.

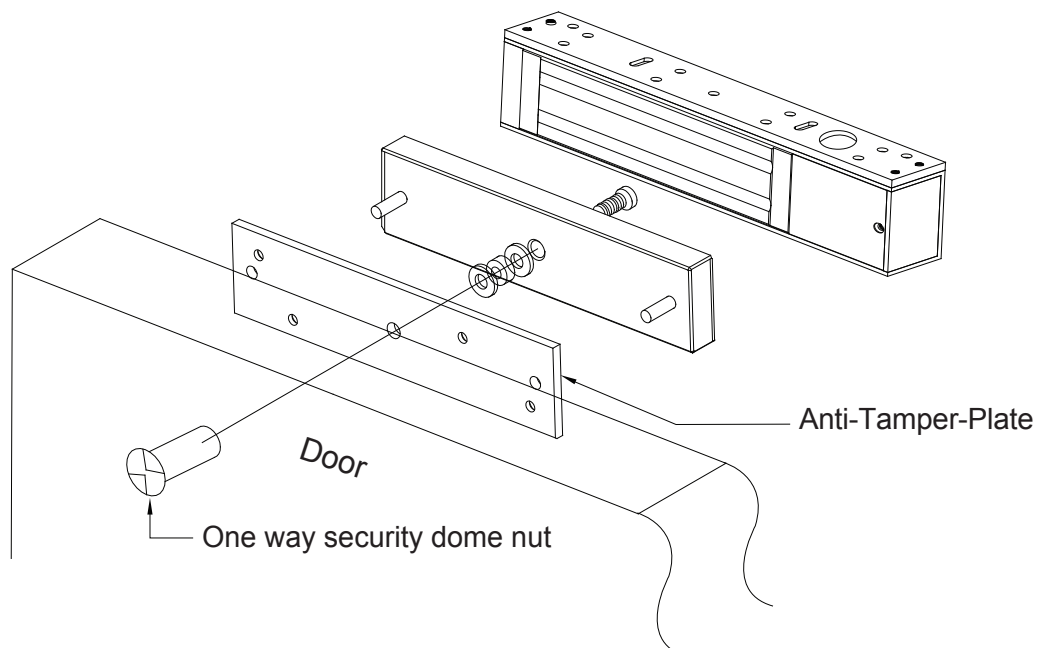

TECHNICAL DATA SHEET

FEM3500 / FEM5700 SERIES MAGNETIC LOCK

REFER TO PAGE 12 OF THE FSH BROCHURE AND/OR FSH WEBSITE FOR CORRECT PART NUMBERS

TYPICAL FIXING OF MAGNETIC LOCK ON IN-SWINGING DOOR

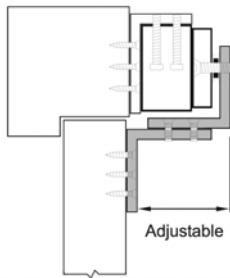

L & Z BRACKET ARRANGEMENT

ARMATURE MOUNTING PLATE DETAIL

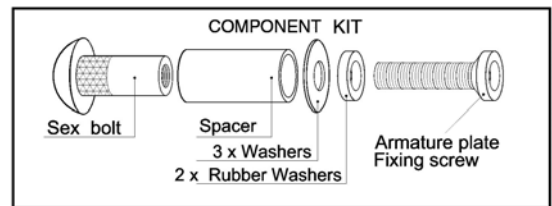

ARMATURE PLATES MUST BE INSTALLED WITH THE COMPONENTS SHOWN ABOVE. THESE COMPONENTS ARE PROVIDED WITH EACH ELECTROMAGNETIC LOCK. (TO AVOID MALFUNCTION OF THE LOCK DO NOT USE PARTS OTHER THAN THOSE PROVIDED ABOVE).

TYPICAL FIXING OF MAGNETIC LOCK ON OUT-SWINGING DOOR

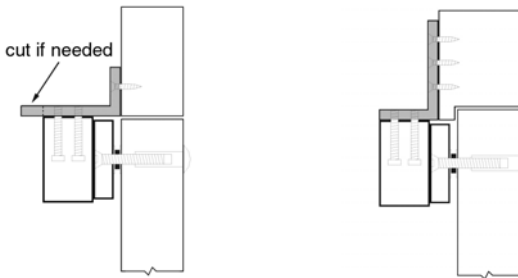

ADJUSTABLE L BRACKET

Adjustable L Bracket is for Flush Transom or Narrow Header.

L BRACKET ARRANGEMENT

L Bracket is for Narrow Header.

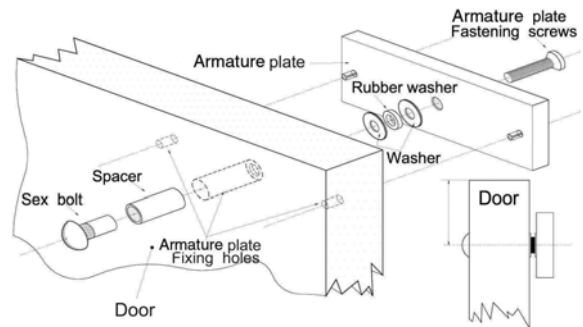

ARMATURE PLATES MUST BE FIXED AS SHOWN ABOVE. DO NOT OVER TIGHTEN THE FIXING SCREW. THE ARMATURE MUST BE ALLOWED TO 'FLOAT' ON THE RUBBER WASHER.

METHODS OF FIXING MAGNETIC LOCKS ON DIFFERENT FRAME PROFILES

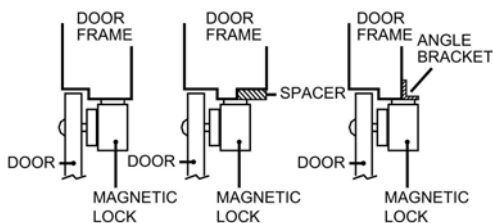

FIXING ARMATURE PLATE ON FRAMELESS GLASS DOORS

